

Solid/liquid dual-purpose Sake lees vacuum distillation equipment

SVD-N type

First in Japan ! Distillation of sake lees using microwaves (Patented equipment)

The heat source is all electric, and no boiler is required !

- Sake lees, Rice flour fermentation mash, Sake lees fermentation mash, Alcohol recovery from sake, etc.
- For adding rice-based alcohol, For a variety of other applications such as shochu production.
- No distillation expertise required, Energy-saving distillation at human skin temperature.
- Easy to operate and space-saving, Automatic stop timer allows up to 4 distillation runs per day.
- As long as you have fresh sake lees, you can immediately produce mellow shochu.
- Dry vacuum pump that does not use any water to achieve higher quality shochu production.
- Three types are available: 100kg type, 200kg type, and 300kg type per time.
- Vacuum distillation in a liquid state is also possible with the option of a dedicated tank.



SVD-100N(Paint Black Options)



SVD-280N



Tray for lees Cooling system Distillation equipment



Scene of sake lees preparation

Operating Instructions (at the time of distillation of sake lees)

Loosen the sake lees and place them in a white tray.

After arranging them on a rotating table in the device, the table lift is raised and put into the main unit.

After the vacuum pump is operated, it is distilled by microwave heating.

You do not need to be present during distillation.

After the distillation is completed, the vacuum is released, the table is lowered, and the entire tray is drained (the remaining sake lees are in a half-raw state).

On average, about 15 L of shochu can be collected from 100 kg of sake lees (It varies depending on the type and condition of the lees).

Average distillation time : approx. 2 hours (= It can be distilled 2 to 4 times per day).

Equipped with automatic stop function by timer as standard.

Variety of options

- Additional, sorting receiver tank (Head, Tail, etc.)
- Low-temperature brine cooling system (recovered at $-5^{\circ}\text{C}\sim-10^{\circ}\text{C}$)
- Shochu filtration unit (pump with microfilter)
- Spare PP tray (continuous processing)
- PP tank for liquid distillation, large stainless steel tank



SVD-200N Chiller unit (optional)

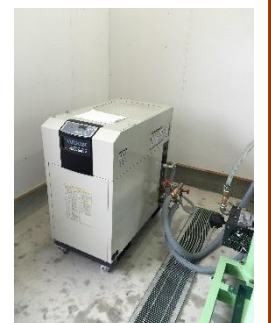

SVD-100N Chiller unit (optional)

Sake lees vacuum distillation equipment: SVD-N type

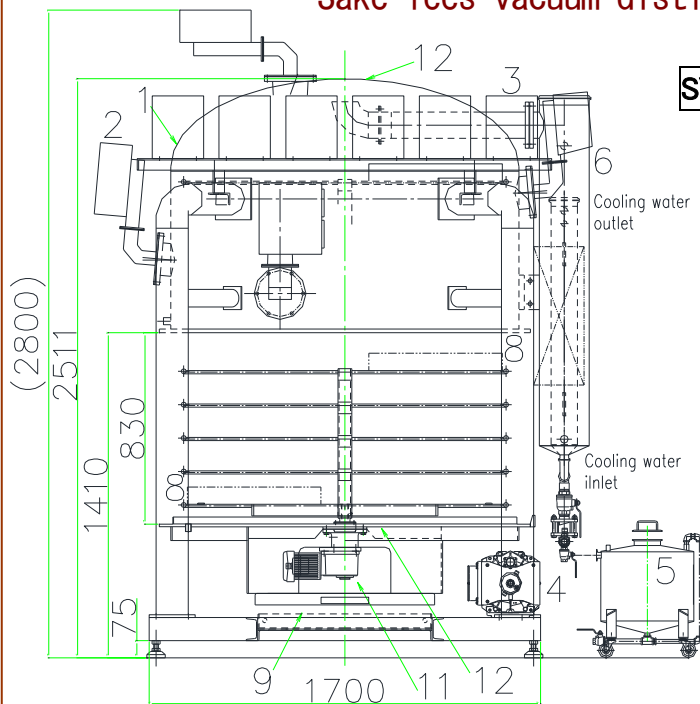

SVD-200N

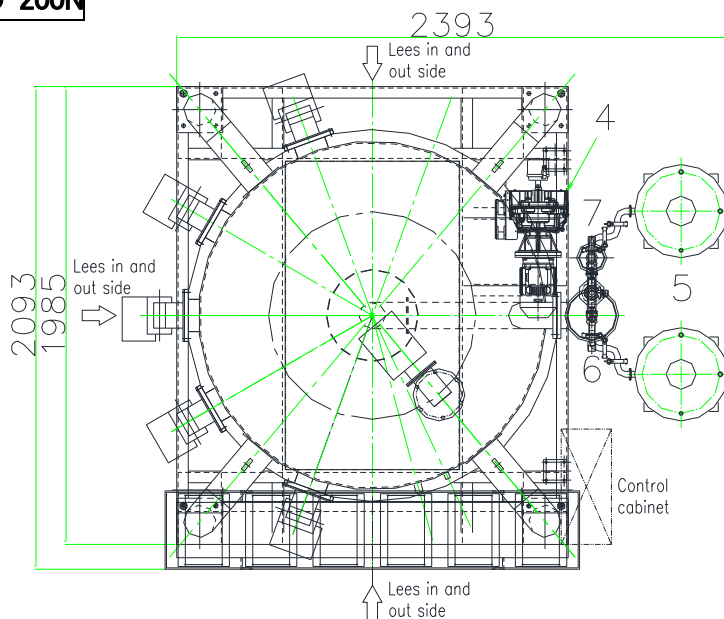

~Example of recovery rate calculation~

Assuming that the alcohol content of the sake lees before squeezing

is 17 % and the solids content in the lees after squeezing is 50 Weight

%, then about 8 % alcohol is contained in this sake lees.

* As a manufacturing prospectus When 200 kg of sake lees is distilled twice a day and collected as shochu at a distillation rate of 85 %

$200 \times 0.08 \times 0.85 \times 2 = 27.2$ L (as pure alcohol) \rightarrow In 25% conversion, $27.2 \div 0.25 = 108.8$ L (60 bottles of 1.8 L bottles).

No.	Name	Qty.	Materials	No.	Name	Qty.	Materials
1	Main body of the device	1	SUS304 main	7	2nd Condenser	1	SUS304
2	Microwave Oscillator	6		8	PP Tray	30	P.P
3	Microwave Power supply	6		9	Table Lifter	1	
4	Oil-free dry vacuum pump	1		10	Common base	1	SS400
5	Receiver tank	2	SUS304	11	Rotary shelf reduction motor	1	
6	1st Condenser	1	SUS304	12	Heater(bottom,cealing)	1set	



We also have a variety of vacuum and atmospheric distillation equipment dedicated to liquids (mash / sake).

In addition to this, please feel free to ask anything about shochu equipment such as rice flour saccharification equipment and granular activated carbon filter.



PP tank for liquid distillation



Touch panel control cabinet



Easy to operate



Microfiltration pump

◆ Summary

Specifications/Model	SVD-100N	SVD-200N	SVD-280N
Throughput(kg/1time)	100	200	300
Power Consumption(kW 200V)	8	11	13
Cooling water(ton/h)(below 5°C)	4	8	8
External dimensions	2000*2000*2800H	2100*2400*2900H	2300*2600*3400H

● Due to product improvement, there is a possibility of specification change without notice.

● Design/Production/Distributor

● Agency

Yokoyama Engineering Co., Ltd.

〒452-0822 Nakaotai 3-247, Nishi-ku, Nagoya-shi, Aichi Japan

Tel: 052-505-5911 Fax: 052-505-5915

Email: sakefor@gmail.com URL: <https://www.yokoyama-eng.com>